

SV Series

12W 4:1 Regulated Single & Dual output

Features

- Wide 4:1 Input Range
- Full SMD Technology
- 1600 VDC Isolation
- Efficiency up to 90%
- -40 ~ 85 °C Operation Temperature Range
- No Minimum Load Required
- Continuous Short Circuit Protection
- Over Voltage Protection
- Over Load Protection
- Low no load Input Current
- Soft Start
- High Power Density: 12W in DIL-24 Package
- Remote On/Off



The SV series are high performance 12W single & dual output DC-DC converters. These converters are consisted with nickle-coated copper 24-pin DIL package with high performance features such as synchronous rectification, high efficiency and tight line / load regulation. Devices are encapsulated using flameretardant resin. Input voltages of 24 and 48 with output voltage of 3.3, 5.1, 12, 15, ±5, ±12, ±15Vdc. Features include high efficiency operation up to 90% .

ALL SPECIFICATIONS ARE TYPICAL AT 25°C, NOMINAL INPUT AND FULL LOAD UNLESS OTHERWISE NOTED.

OUTPUT SPECIFICATIONS	
Output Voltage Accuracy	±1.2%
Maximum Output Current	See table
Line Regulation	±0.2%, max
Load Regulation (0% Load to Full Load) Single	±0.5%, max
Load Regulation (0% Load to Full Load) Dual	±1.0%, max
Cross Regulation (Dual Output) (1)	±5%
Ripple&Noise (2)	85mVpk-pk, max
Over Voltage Protection (Zener diode clamp)	3.3V output 3.9V 5.1V output 6.2V 12V output 15V 15V output 18V ± 5V output ±6.2V ±12V output ±15V ±15V output ±18V
Over Load Protection	170% of FL,typ
Short Circuit Protection	Indefinite(hiccup) (Automatic Recovery)
Temperature Coefficient	±0.02%/°C
Capacitive Load (3)	See table
Transient Recovery Time (4)	250us, typ
Transient Response Deviation(4)	±3%, max

INPUT SPECIFICATIONS	
Input Voltage Range	See table
Start up Time (Nominal Vin and constant resistive load)	20mS, typ
Input Filter	Pi Type
Input Current(No-Load)	See table, max
Input Current(Full-Load)	See table, typ
Input Reflected Ripple Current	20mApk-pk
Remote On/Off (CTRL)	ON: 3.0 ... 12Vdc or open circuit OFF: 0 ... 1.2Vdc or Short circuit pin1 and pin 2/3 OFF idle current: 5.0 mA typ

ENVIRONMENTAL SPECIFICATIONS	
Operating Ambient Temperature	-40°C ~ +85°C(See Derating Curve) -40°C ~ +60°C(For 100% load)
Maximum Case Temperature	105°C
Storage Temperature	-40°C ~ +125°C
Cooling	Nature Convection

GENERAL SPECIFICATIONS	
Efficiency	See table, min
I/O Isolation Voltage(3 sec)	
Input/Output	1600Vdc
Case/Input & Output	1600Vdc
Isolation Resistance	1000 MΩ, min
Isolation Capacitance	1500 pF, max
Switching frequency	270kHz, typ
Humidity	95% rel H
Reliability Calculated MTBF(MIL-HDBK-217 F)	>1 Mhrs
Safety Standard : (designed to meet)	IEC 60950-1:2001

EMC CHARACTERISTICS		
Radiated Emissions	EN55022	CLASSA
Conducted Emissions(5)	EN55022	CLASSA
ESD	EN61000-4-2	Perf. Criteria B
RS	EN61000-4-3	Perf. Criteria A
EFT (6)	EN61000-4-4	Perf. Criteria B
Surge (6)	EN61000-4-5	Perf. Criteria B
CS (6)	EN61000-4-6	Perf. Criteria A
PFMF	EN61000-4-8	Perf. Criteria A

PHYSICAL SPECIFICATIONS	
Case Material	Copper with nickel plated
Base Material	Non-conductive black plastic (UL94V-0 rated)
Pin Material	Ø0.5mm Brass Solder-coated
Potting Material	Epoxy (UL94V-0 rated)
Weight	18.0g
Dimensions	1.25"x0.8"x0.40"

ABSOLUTE SPECIFICATIONS (7)		
These are stress ratings. Exposure of devices to any of these conditions may adversely affect long-term reliability.		
Input Surge Voltage(1000mS)	24 Models	-0.7Vdc~50Vdc
	48 Models	-0.7Vdc~100Vdc
Models Lead Soldering Temperature(1.5mm from case 10 sec.)		260°C

SV - 12W 4:1 Regulated Single & Dual output

PART NUMBER STRUCTURE

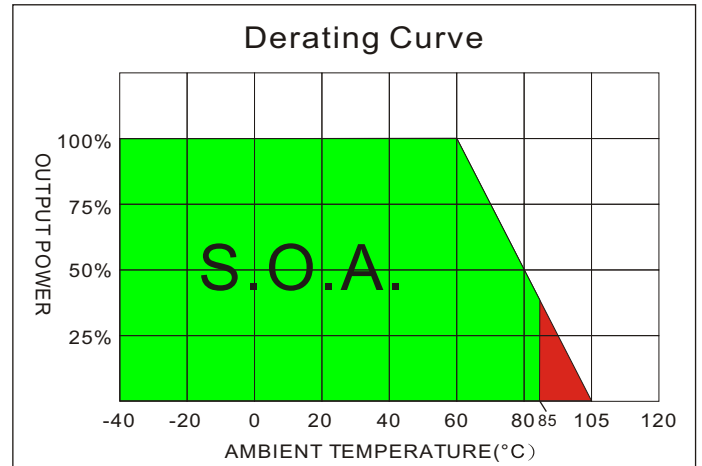
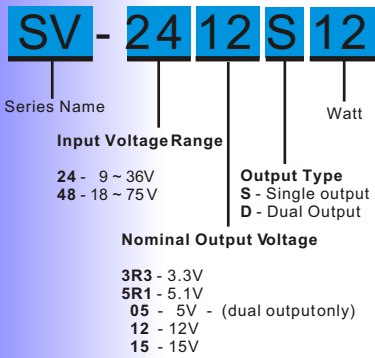

MODEL SELECTION GUIDE

MODEL NUMBER	INPUT Voltage Range (Vdc)	INPUT Current		OUTPUT Voltage (Vdc)	OUTPUT Current		EFFICIENCY @FL(%)	Capacitor Load(uF)
		No-Load (mA)	Full Load (mA)		Min. load (mA)	Full load (mA)		
SV-243R3S12	9-36	15	573	3.3	0	3500	87	2000
SV-245R1S12	9-36	15	581	5.1	0	2400	89	2000
SV-2412S12	9-36	15	574	12	0	1000	90	430
SV-2415S12	9-36	15	574	15	0	800	90	300
SV-2405D12	9-36	15	595	±5	0	±1200	87	±1250
SV-2412D12	9-36	15	574	±12	0	±500	90	±200
SV-2415D12	9-36	15	574	±15	0	±400	90	±120
SV-483R3S12	18-75	15	286	3.3	0	3500	87	2000
SV-485R1S12	18-75	15	290	5.1	0	2400	89	2000
SV-4812S12	18-75	15	287	12	0	1000	90	430
SV-4815S12	18-75	15	287	15	0	800	90	300
SV-4805D12	18-75	15	297	±5	0	±1200	87	±1250
SV-4812D12	18-75	15	287	±12	0	±500	90	±200
SV-4815D12	18-75	15	287	±15	0	±400	90	±120

NOTE

1. One load is 25% to 100% load, the other load is 100% load, the output voltage variable rate is within ±5%.
2. Measured with 20MHz bandwidth and 1.0uF ceramic capacitor.
3. Tested by minimal Vin and constant resistive load.
4. Tested by normal Vin and 25% load step change (75%-50%-25% of Io).
5. Input filter components (C1, L, C2) are used to help meet conducted emissions requirement for the module. These components should be mounted as close as possible to the module; and all leads should be minimized to decrease
6. An external filter capacitor is required if the module has to meet EN61000-4-4 and EN61000-4-5 and EN61000-4-6 . The filter capacitor Motien suggest: Nippon - chemi - con KY series, 330uF/100V.
7. Exceeding the absolute ratings of the unit could cause damage. It is not allowed for continuous operating.

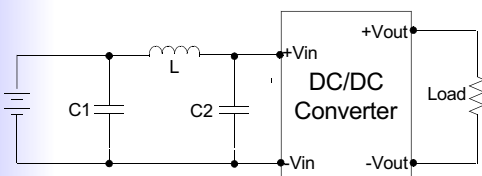

	C1	L	C2
VV-24XXXXX	2.2uF, 100V	12uH	2.2uF, 100V
VV-48XXXXX	2.2uF, 100V	12uH	2.2uF, 100V

TEST CONFIGURATIONS

Input Reflected Ripple Current Test Step

Input reflected ripple current is measured through a source inductor L_{in} (12uH) and a source capacitor C_{in} (47uF, ESR<1.0Ω at 100KHz) at nominal input and full load.

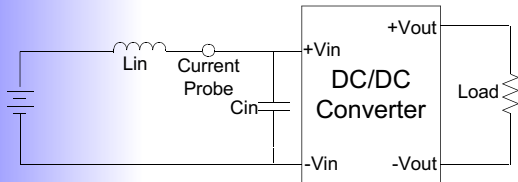

Output Ripple & Noise Measurement Test

Use a capacitor C_{out} (1.0uF) measurement. The Scope measurement bandwidth is 0-20MHz.

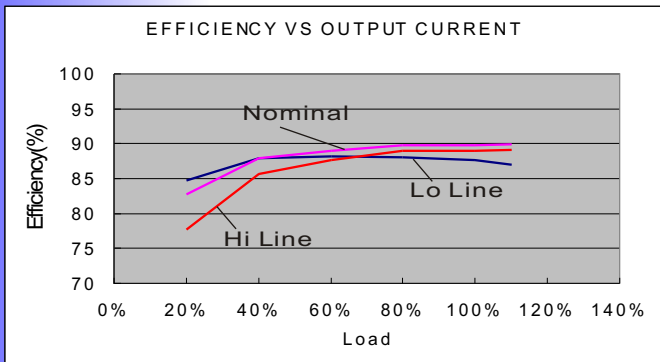
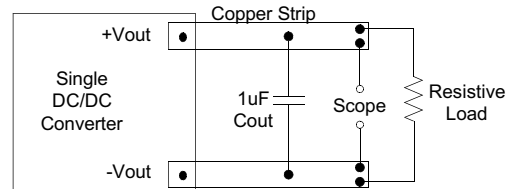

SV-245R1S12

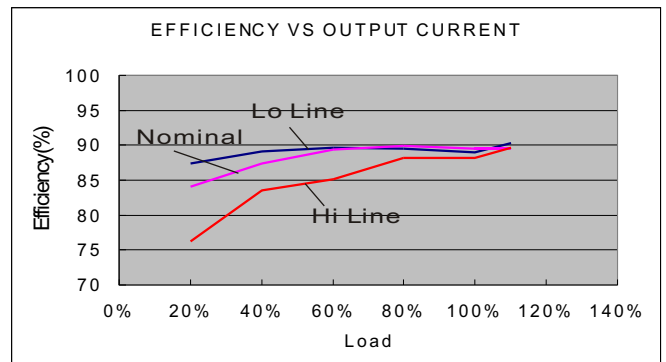

SV-4812S12

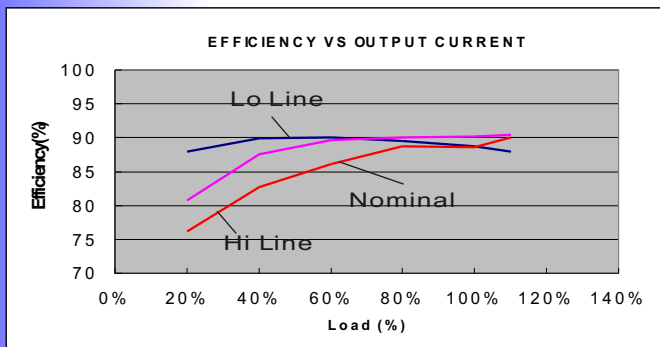

SV-2412D12

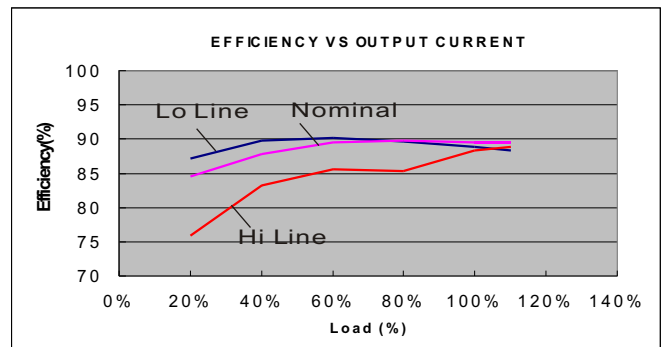

SV-4815D12

SV - 12W 4:1 Regulated Single & Dual output

MECHANICAL SPECIFICATIONS

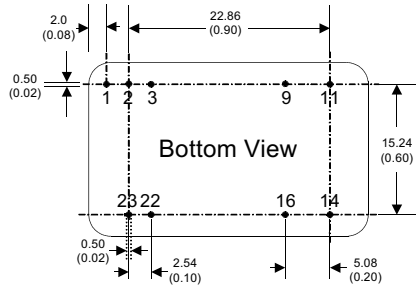
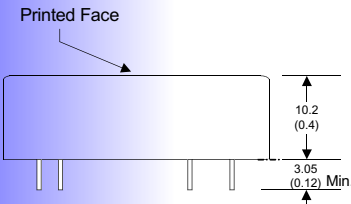
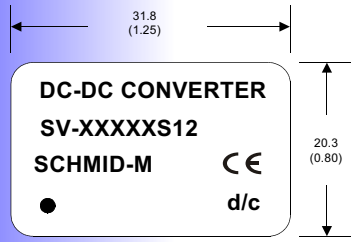

**24 Pin DIL Package
Nickel-Coated Copper**

Notes :

- All dimensions are typical in millimeters (inches).
1. Pin diameter: 0.5 ±0.05 (0.02 ±0.002)
 2. Pin pitch tolerance: ±0.35 (±0.014)
 3. Case Tolerance: ±0.5 (±0.02)

PIN CONNECTIONS		
PIN NUMBER	SINGLE	DUAL
1	Remote On/Off	Remote On/Off
2	-V Input	-V Input
3	-V Input	-V Input
9	N.P.	Common
11	N.C.	-V Output
14	+V Output	+V Output
16	-V Output	Common
22	+V Input	+V Input
23	+V Input	+V Input