

SULA Series

High Efficiency Step-UP LED Driver



Features

- RoHS-compliant 2"x1" case Package Power LED Driver
- Constant Current Output (±5% Output Current Accuracy)
- LED Driver Current 150 / 250 / 300 / 350 / 500 / 600 / 700 mA
- Power LED Driver
- Wide Input Voltage Range: 9V to 36V (38V for 0.1sec.)
- Output Power 7.2 / 12 / 14.4 / 16.8 / 24 / 28.8 / 33.6 W
- Driver LED Strings of up to 48V (14V to 48V)
- High Efficiency (up to 95%)
- PWM/Digital Dimming and Analog Voltage Dimming
- Open and Short LED Protection
- Pin or Wire Versions
- -40°C ~ 85°C Operation Temperature Range
- IP67 rated for Wired Version
- With MLCC Capacitors only



Application

- 12V / 24V Solar Lighting Systems
- Household/Commercial lighting
- Suitable for high illumination LED
- Power limited (battery) lighting system

SULA series is a high efficiency step-up converter optimized to drive high current LEDs. The control algorithm allows highly efficient and accurate LED current regulation. The device operates from an input 9Vdc to 36Vdc and provides an externally adjustable output current of up to 700mA and output power up to 33.6 watts. Compact size of 2"x1" case allows designer to integrate this driver together with LED module. UL94V-0 grade molded case with high grade filling material provide excellent fire proof characteristics.

(Typical at Ta = +25°C, nominal input voltage, rated output current unless otherwise specified.)

Electrical Specifications	
Input Voltage (Vdc)	9V ~ 36V, 24V typ.
Input Filter	Capacitor
Output Voltage Range (Vo - Vin ≤ 5V) (1)	14V to 48V
Output Current Range (Vo - Vin ≤ 5V)	See table
Output Current Accuracy	±5%
Output Power (2)	See table
Ripple and Noise, (20 MHz bandwidth)	See table
Efficiency	See table
Capacitive Load (3)	See table
Operating Frequency	370KHz typ.
Over Voltage Protection (OVP)	52.5V Max.
Short Circuit Protection (4)	Automatic Recovery (Cut-off output)
Under Voltage Protection (Cool Start) (5)	7.6V typ.
Soft Start Time (Not to increase additional output capacitor)	50mS Max.
Temperature Coefficient (Ta = -40°C to +85°C)	±0.03%/°C Max.
Thermal Impedance (Nature Convection)	+17°C/W
Safety Standard : (designed to meet)	IEC/EN 60950-1 UL8750 and IEC/EN 61347-2-13

Environmental Specifications	
Operating Temperature Range, Ta	-40°C to +85°C (See Derating Curve)
Storage Temperature Range	-55°C to +125°C
Humidity	95% rel H
Water Resistance (Wired Version only)	IP67
Maximum Case Temperature	+102°C
Cooling	Nature Convection
Reliability Calculated MTBF (MIL-HDBK-217 F)	>1.29Mhrs
Soldering Temperature (1.5mm from case 10 sec. Max.)	+260°C, Max.

ON/OFF Control (Leave Open if Not Used): (EN)	
DC/DC ON	Open
DC/DC OFF (Shutdown)	0V
Remote Pin Drive Current (VEN ≤ 3V)	<1.5uA
Quiescent Input Current in Shutdown Mode (Vin 9V~32V)	1.3mA Max.
(Vin 32V~36V)	8mA Max.

Analog and PWM Dimming Control (Leave Open if Not Used): (DIM)	
Absolute Maximum Ratings	8V
Analog Dimming Control	
DIM Input Voltage Range	0.4V to 1.7V
Adjust Output Current	0% to 100%
DIM Pin Drive Current (0.3V ≤ VD _{DIM} ≤ 1.3V)	<1.5uA
PWM Dimming Control (6)	
PWM Control Voltage Range Limits (1.7V ≤ VD _{DIM} ≤ 5.0V)	
Recommended Operation Frequency	100Hz~100KHz
Adjust Output Current	0% to 100%

Physical Specifications	
Case Material	Non-conductive Black Plastic (UL94V-0 rated)
Potting Material	Epoxy (UL94V-0 rated) Silicon (UL94V-0 rated)
Pin Material	Ø1.0mm Brass Solder-coated
Lead Wires	UL 1015/CSA TEM listed/ 18AWG / 600V/ 105°C Rated UL 1015/CSA TEM listed/ 22AWG / 600V/ 105°C Rated
Weight (Pinned / Wired)	38g / 44.2g
Dimensions	51.5(L)"x26.1(W)"x15.8(H)"mm

EMC Specifications (designed to meet)	
EMI Radiated & Conducted Emissions	EN 55022 Class B

NOTE

1. To prevent the burned out of driver, The output voltage must be 5.0Vdc higher than input voltage.
2. DO NOT operate the driver over output power.
3. The Output ripple has been rather low, it's recommended not to increase the additional output capacitor, otherwise there will be time delay while starting up under cool starting.
4. There is protection while output is shorted, after the short occurs, input current will be cut off and recover while short is removed.
5. The reference value of under voltage protection -- 7.6V means under the condition of cool start and full discharge of output, protection starts when input voltage is lower under 7.6V.
6. Please note, PWM dimming means PWM signals is converted into mimic analog voltage by internal circuits and then do the dimming. The advantage of such approach is to reduce the EMI.

The information and specifications contained in this data sheet are believed to be correct at time of publication. However, Schmid-Multitech accepts no responsibility for consequences arising from printing errors or inaccuracies. Specifications are subject to change without notice. No rights under any patent accompany the sale of any such product(s) or information contained herein.

PART NUMBER STRUCTURE

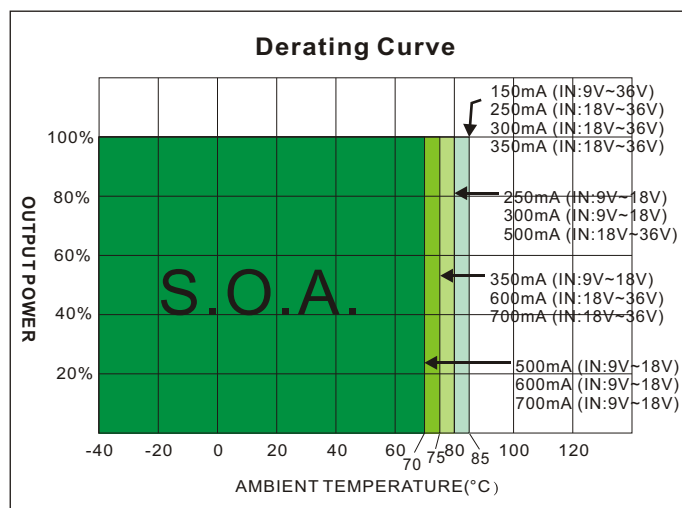
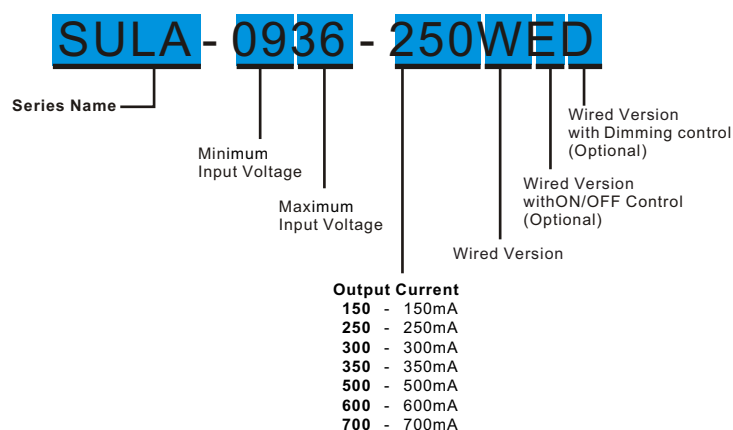

MODEL SELECTION GUIDE

MODEL NUMBER	INPUT	OUTPUT		OUTPUT Current Accuracy (%)	OUTPUT Power (W) Max.	EFFICIENCY @FL (%) Max.	Ripple and Noise mVp-p Max.	Capacitor Load (uF)
	Voltage Range (Vdc)	Voltage Range (Vdc)	Current (mA)					
SULA-0936-150	9 - 36	14 - 48	150	±5	7.2	86 - 91	350	100
SULA-0936-250	9 - 36	14 - 48	250	±5	12.0	89 - 93	450	100
SULA-0936-300	9 - 36	14 - 48	300	±5	14.4	89 - 94	450	100
SULA-0936-350	9 - 36	14 - 48	350	±5	16.8	89.5 - 94	600	100
SULA-0936-500	9 - 18	14 - 45	500	±5	24.0	90 - 95	650	47
	18 - 36	23 - 48						
SULA-0936-600	9 - 18	14 - 38	600	±5	28.8	91 - 95	650	47
	18 - 36	23 - 48						
SULA-0936-700	9 - 18	14 - 32	700	±5	33.6	91.5 - 95	700	47
	18 - 36	23 - 48						
SULA-0936-150 WED	9 - 36	14 - 48	150	±5	7.2	86 - 91	350	100
SULA-0936-250 WED	9 - 36	14 - 48	250	±5	12.0	89 - 93	450	100
SULA-0936-300 WED	9 - 36	14 - 48	300	±5	14.4	89 - 94	450	100
SULA-0936-350 WED	9 - 36	14 - 48	350	±5	16.8	89.5 - 94	600	100
SULA-0936-500 WED	9 - 18	14 - 45	500	±5	24.0	90 - 95	650	47
	18 - 36	23 - 48						
SULA-0936-600 WED	9 - 18	14 - 38	600	±5	28.8	91 - 95	650	47
	18 - 36	23 - 48						
SULA-0936-700 WED	9 - 18	14 - 32	700	±5	33.6	91.5 - 95	700	47
	18 - 36	23 - 48						

MECHANICAL DIMENSION

Pinned Version

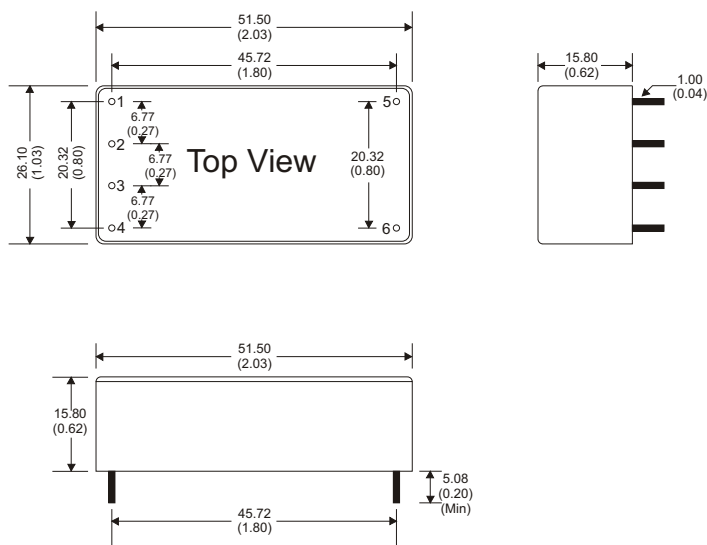

PIN CONNECTIONS		
PIN #	CONNECTIONS	
1	+Vi	+DC Supply
2	DIM	PWM/ Analog Dimming Control
3	EN	Remote ON/OFF
4	-Vi	-DC Supply (GND)
5	+ LED	LED Anode Connection
6	- LED	LED Cathode Connection

All dimensions are typical in millimeters (inches)
 1. Pin diameter: 1.0 ±0.05 (0.04 ±0.002)
 2. Pin pitch tolerance: ±0.35 (±0.014)
 3. Case Tolerance: ±0.5 (±0.02)

Wired Versions

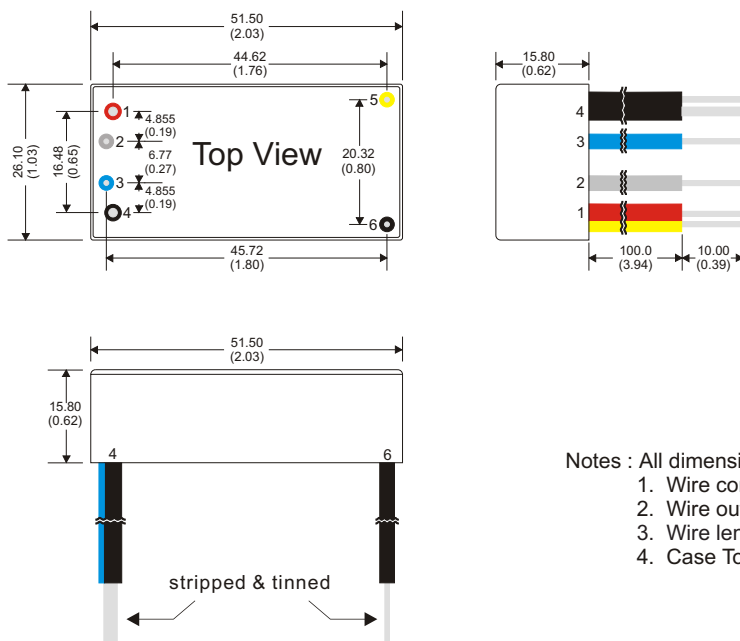

CONNECTIONS		
Wires #	CONNECTIONS	
1 (Red)	+Vi	+DC Supply
2 (White)	DIM	PWM/ Analog Dimming Control
3 (Blue)	EN	Remote ON/OFF
4 (Black)	-Vi	-DC Supply (GND)
5 (Yellow)	+ LED	LED Anode Connection
6 (Black)	- LED	LED Cathode Connection

Notes : All dimensions are typical in millimeters (inches).
 1. Wire core diameter: 0.80±0.1 (0.031±0.004) & 1.40±0.1 (0.055±0.004)
 2. Wire outside diameter: 2.4±0.1 (0.094±0.004) & 2.7±0.1 (0.106±0.004)
 3. Wire length = 100 + 10 stripped & tinned = 110±5 (4.33±0.197) total
 4. Case Tolerance: ±0.50 (±0.02)

The information and specifications contained in this data sheet are believed to be correct at time of publication. However, Schmid-Multitech accepts no responsibility for consequences arising from printing errors or inaccuracies. Specifications are subject to change without notice. No rights under any patent accompany the sale of any such product(s) or information contained herein.

Typical Operating Conditions

SULA-0936-150

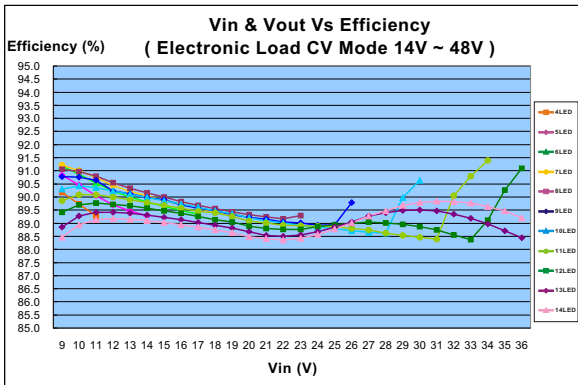

SULA-0936-500

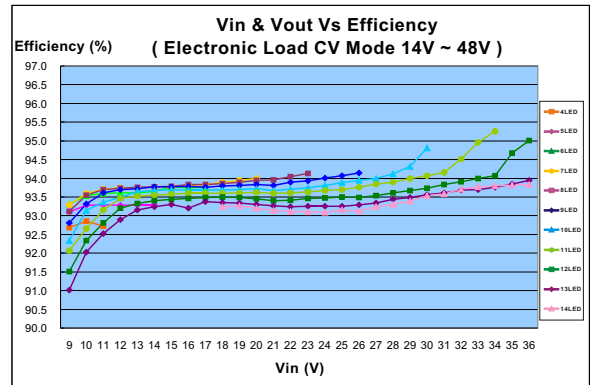

SULA-0936-250

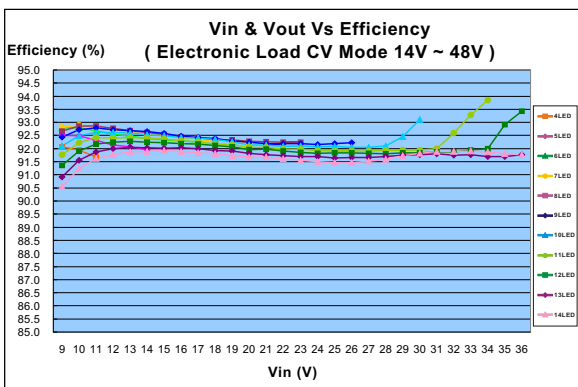

SULA-0936-600

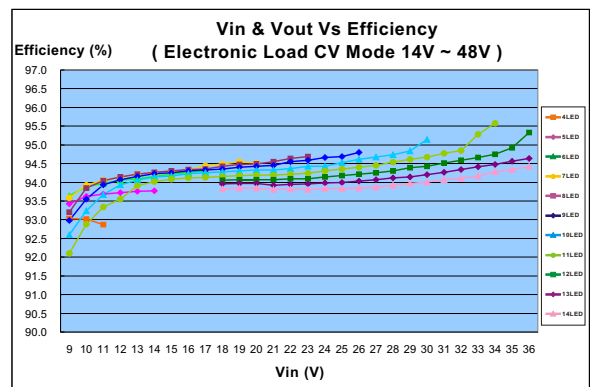

SULA-0936-300

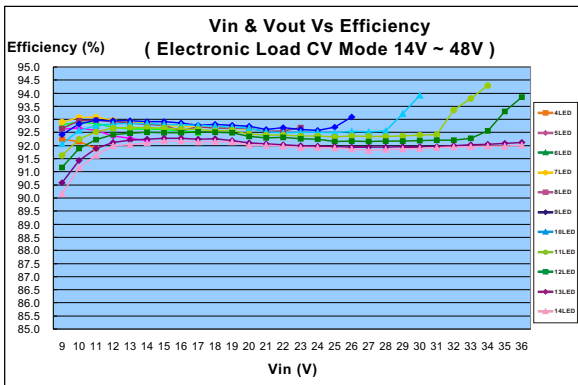

SULA-0936-700

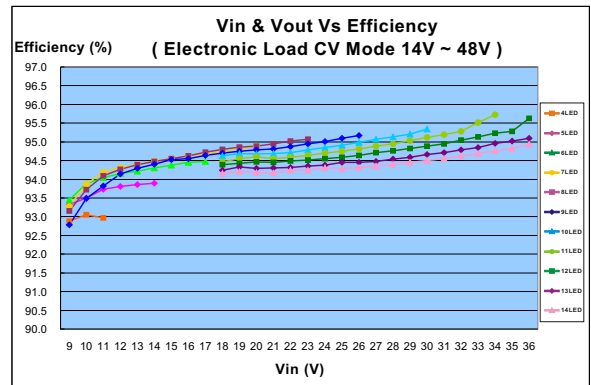

SULA-0936-350

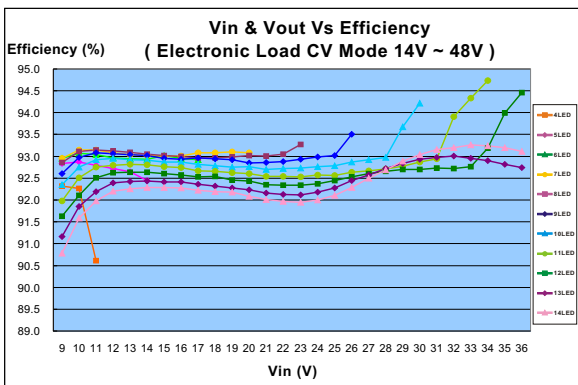

The information and specifications contained in this data sheet are believed to be correct at time of publication. However, Schmid-Multitech accepts no responsibility for consequences arising from printing errors or inaccuracies. Specifications are subject to change without notice. No rights under any patent accompany the sale of any such product(s) or information contained herein.

EMC Characteristics meet EN55022

EN55022 Class B Filter Suggestion:

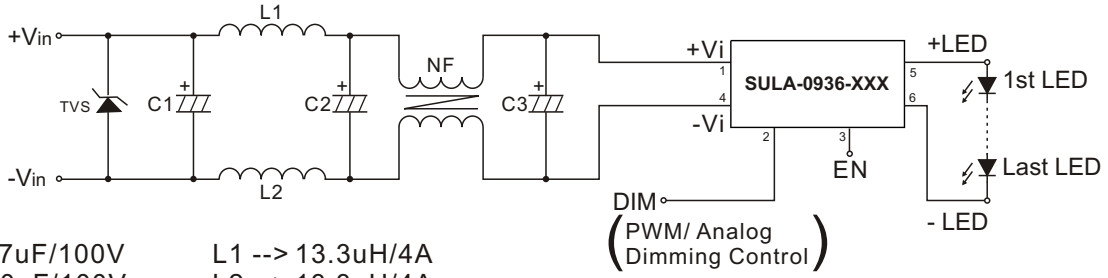

- C1 ----> 47uF/100V
- C2 ----> 330uF/100V
- C3 ----> 330uF/100V
- TVS --> 38V
- L1 --> 13.3uH/4A
- L2 --> 13.3uH/4A
- NF--> 3.0mH/4A(Command choke)

Conducted Emissions Test

Vin=24V Vout=48V(LED Load Vf=3.5V · 14LED ≐ 48V)
POLARITY:NEUTRAL

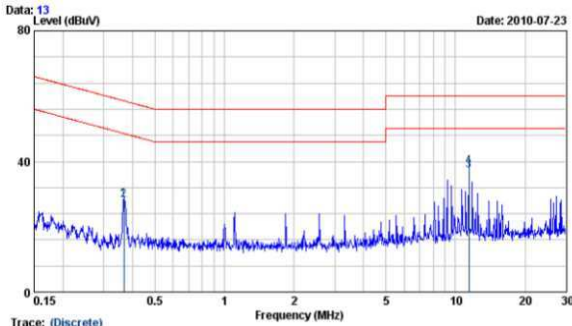

Freq. MHz	LISN Factor dB	Cable Loss dB	Meter Reading dBuV	Measured Level dBuV	Limits dBuV	Over Limits dBuV	Detector
0.367	9.81	0.02	18.39	28.22	58.56	1-30.35	QP
0.367	9.81	0.02	18.34	28.17	48.56	1-20.40	AVERAGE
11.405	10.30	0.13	26.73	37.16	50.00	1-12.84	AVERAGE
11.405	10.30	0.13	27.92	38.35	60.00	1-21.65	QP

REMARKS: 1.Level(dBuV)=Read Level(dBuV)+LISN Factor(dB)+Cable loss(dB)
2.Over Limit value(dB)=Level(dBuV)-Limit Line(dBuV)

Vin=24V Vout=48V(LED Load Vf=3.5V · 14LED ≐ 48V)
POLARITY:LINE

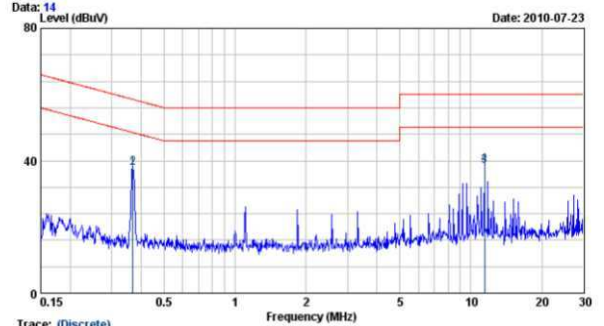

Freq. MHz	LISN Factor dB	Cable Loss dB	Meter Reading dBuV	Measured Level dBuV	Limits dBuV	Over Limits dBuV	Detector
0.369	9.82	0.02	27.72	37.56	58.52	1-20.96	QP
0.369	9.82	0.02	28.11	37.95	48.52	1-10.57	AVERAGE
11.409	10.35	0.13	27.87	38.35	50.00	1-11.65	AVERAGE
11.409	10.35	0.13	28.32	38.80	60.00	1-21.20	QP

REMARKS: 1.Level(dBuV)=Read Level(dBuV)+LISN Factor(dB)+Cable loss(dB)
2.Over Limit value(dB)=Level(dBuV)-Limit Line(dBuV)

Radiation Emissions Test Result

Vin=12V Vout=32V(LED Load Vf=3.5V · 9LED ≐ 32V)
POLARITY:HORIZONTAL

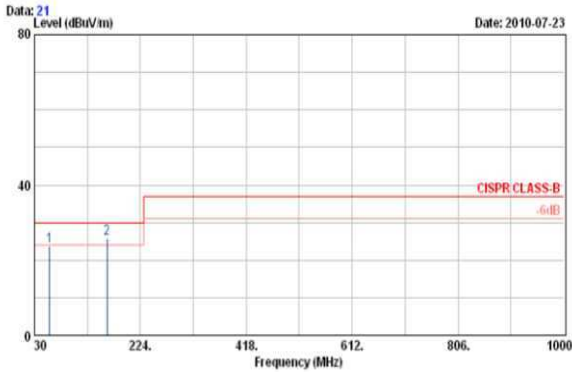

Freq. MHz	Reading dBuV	Antenna Factor dB/m	Cable Loss dB	Measure Level dBuV/m	Limit dBuV/m	Over Limit dBuV/m	Detector
57.50	14.48	7.88	1.41	23.77	30.00	-6.23	QP
162.88	10.46	12.21	3.03	25.70	30.00	-4.30	QP

Vin=24V Vout=48V(LED Load Vf=3.5V · 14LED ≐ 48V)
POLARITY:HORIZONTAL

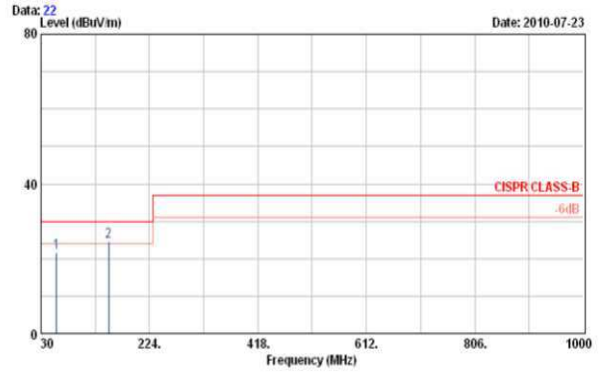

Freq. MHz	Reading dBuV	Antenna Factor dB/m	Cable Loss dB	Measure Level dBuV/m	Limit dBuV/m	Over Limit dBuV/m	Detector
57.83	12.47	7.82	1.44	21.73	30.00	-8.27	QP
150.90	9.12	12.74	2.87	24.73	30.00	-5.27	QP

Typical Application

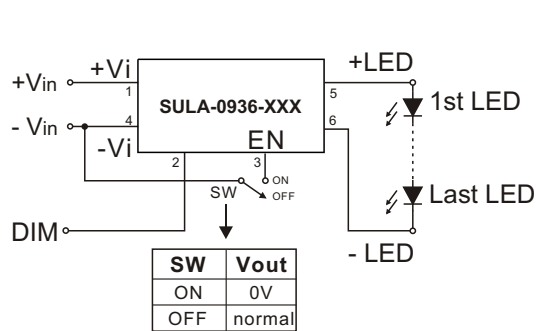
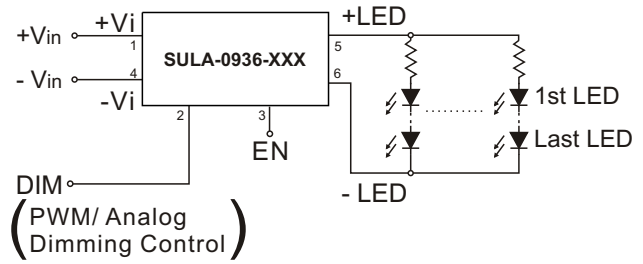
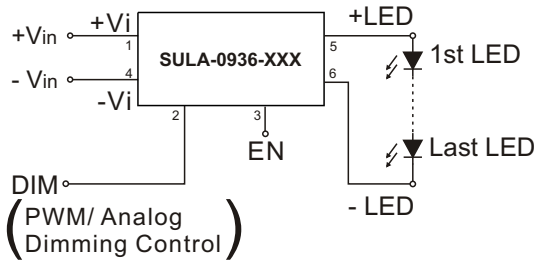
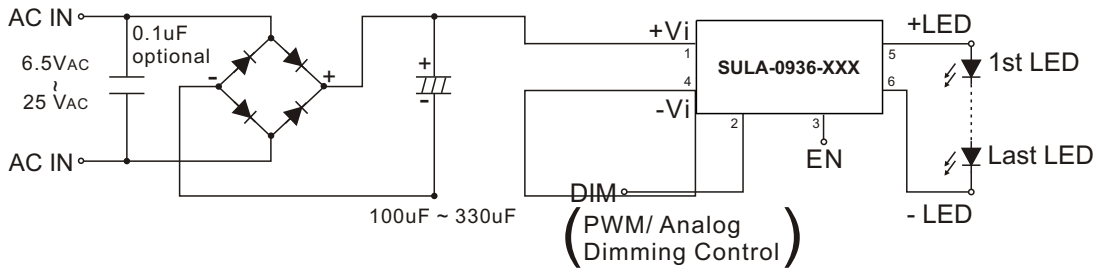

Under Voltage Protection

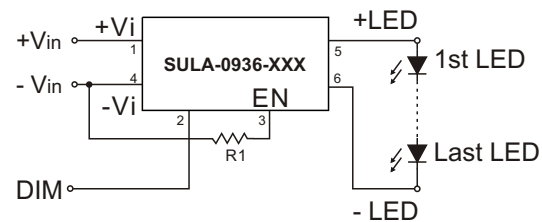

R1	Under Voltage Protection
X	7.6V
12K	10.8V
10K	11.6V
7.5K	13.0V
4.7K	16.5V
3.3K	21.0V
2.7K	24.1V
2.4K	26.2V
2.0K	29.8V
1.8K	32.4V

The R1 Value Only Supplies The Reference

Output Current Adjustment Control By External DC Control Voltage

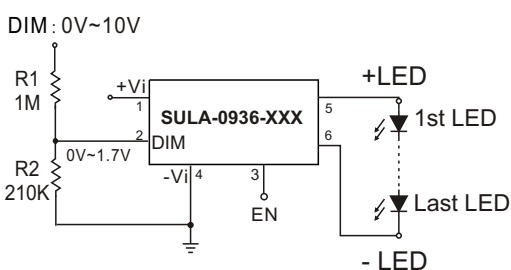
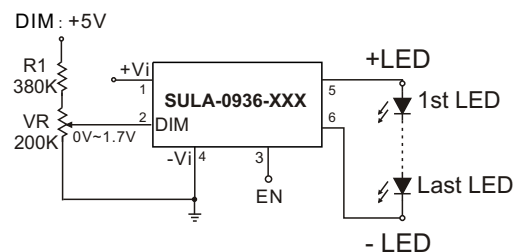
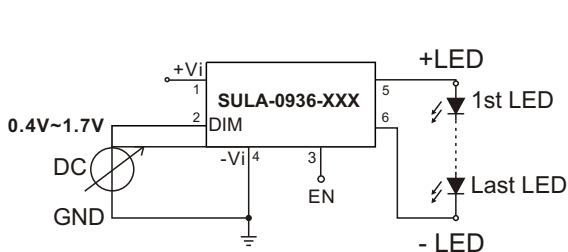

Vin	R1
5V	4.7K
12V	18K
24V	43K
36V	62K

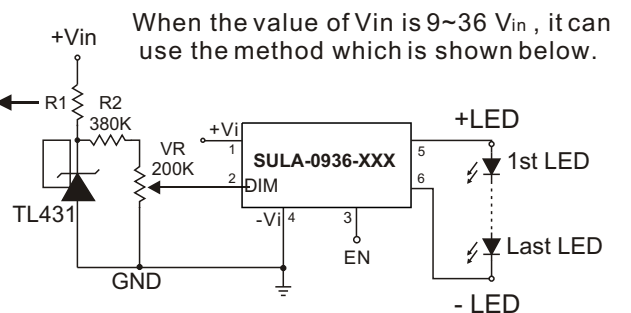

When the value of Vin is 9~36 Vin, it can use the method which is shown below.

The information and specifications contained in this data sheet are believed to be correct at time of publication. However, Schmid-Multitech accepts no responsibility for consequences arising from printing errors or inaccuracies. Specifications are subject to change without notice. No rights under any patent accompany the sale of any such product(s) or information contained herein.

Typical Application

Output Current Adjustment Control By PWM Control

Directly driving DIM input

A Pulse Width Modulated (PWM) signal can be applied to the DIM pin, as shown below

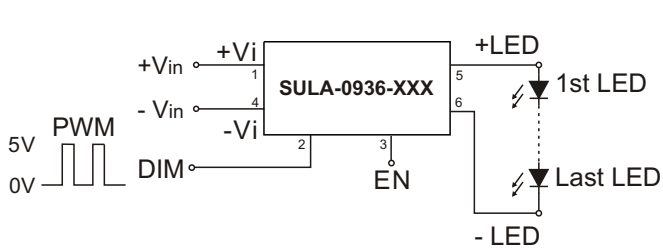

Driving the DIM input via open collector transistor

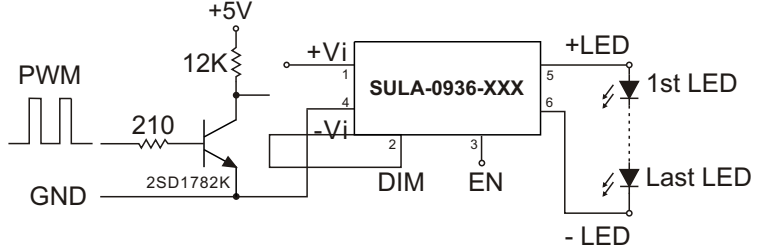

Driving the DIM input from a microcontroller

Another possibility is to drive the device from the open drain output of a microcontroller. The diagram below shows one method of doing this:

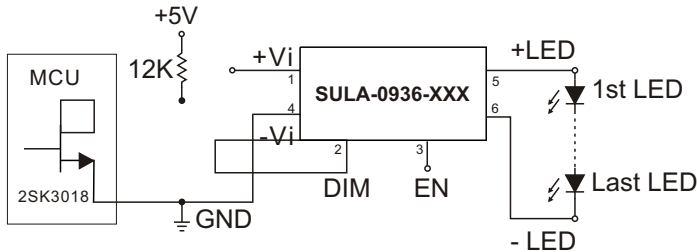

Output Current Adjustment By PWM Control (Dimming)

To avoid visible flicker the PWM signal must be greater than 100Hz.

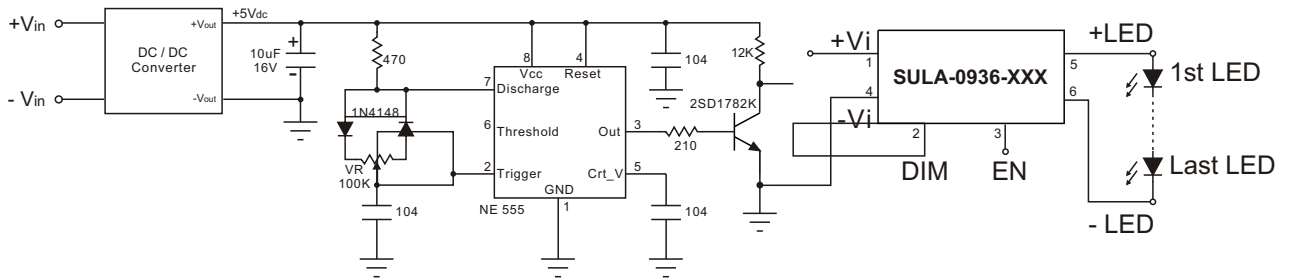

Output Current Adjustment By PWM Control (Flash)

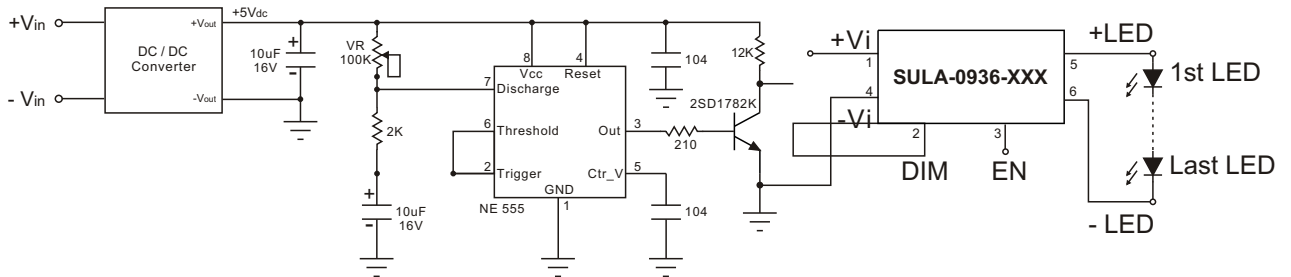

The information and specifications contained in this data sheet are believed to be correct at time of publication. However, Schmid-Multitech accepts no responsibility for consequences arising from printing errors or inaccuracies. Specifications are subject to change without notice. No rights under any patent accompany the sale of any such product(s) or information contained herein.