



## SLD03-05 SERIES

### 3-5W, AC-DC CONVERTER

SLD ---- are high efficiency green power modules with least packaging provided by SCHMID-M. The features of this series are: wide input voltage, DC and AC all in one, high efficiency, high reliability, low loss, safety isolation etc. They are widely used in industrial, office, civil and medical equipments. EMC and safety standards meet international standards IEC61000, EN60950/EN60601 and IEC60950, and Multi-certificate is in processing.



#### PRODUCT FEATURES

1. Universal Input: 85 ~ 264VAC, 50/60Hz
2. AC and DC all in one (input from the same terminal)
3. Low Ripple and Noise
4. Over output voltage protection, short circuit protection and Over temperature
5. High efficiency, High power density
6. Low loss, green power
7. Multiple models available
8. industrial, medical level specifications
9. 3 years warranty

#### MODEL SELECTION

SLD05- 2 0B24

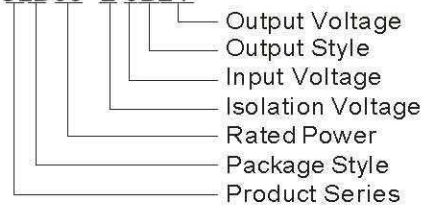

#### PRODUCT PROGRAM

Approval	Model	Package	Power	Output (Vo1/Io1)	Output (Iomax/T)	Ripple and Noise (Max)	Efficiency (% Typ)
UL/CE60950	SLD03-10B03	37.0X23.0X15.0mm	2.3W	3.3V/700mA	900mA/60s	60mV	63
	SLD03-10B05			5V/600mA	750mA/60s		72
	SLD03-10B09		3W	9V/330mA	450mA/60s		74
	SLD03-10B12			12V/250mA	330mA/60s		76
	SLD03-10B15			15V/200mA	250mA/60s		76
	SLD03-10B24			24V/125mA	160mA/60s		78
UL/CE60601	SLD05-20B03	50.8X25.4X15.16mm	4.2W	3.3V/1250mA	1400mA/60s	60mV	66
	SLD05-20B05			5V/1000mA	1300mA/60s		72
	SLD05-20B09		5W	9V/550mA	700mA/60s		74
	SLD05-20B12			12V/420mA	550mA/60s		76
	SLD05-20B15			15V/333mA	450mA/60s		76
	SLD05-20B24			24V/230mA	300mA/60s		78

Note:

1. Ripple and Noise were measured by the method of anear measure (The details see the anear measure);
2. Unless otherwise specified, all specifications above are measured at rated input voltage and rated output load, TA=25°C, humidity < 75%;
3. All specifications stated in this datasheet are subject to the above listed models only. For specifications of non-standard models, please contact our technical support team.
4. Product can not be operated continuously over current, or it will cause permanent damage to the device.

#### INPUT SPECIFICATIONS

Input Voltage Range	85~264VAC, 110~370VDC	
Input Frequency	47~440Hz	
Input Current	SLD03 models SLD05 models	110VAC 65mA, typ 110mA, typ 230VAC 30mA, typ 70mA, typ
Inrush Current	SLD03 models SLD05 models	110VAC 10A, typ 10A, typ 230VAC 20A, typ 20A, typ
External input fuse (Recommended)	SLD03 models SLD05 models	0.5A/250V Slow blow 1A/250V Slow blow

## OUTPUT SPECIFICATIONS

Voltage set accuracy		±2% (typ) (±3%@3.3V output )
Input variation		±0.5% (typ)
Load variation (10% to 100%)		±1% (typ)
Ripple& noise(p-p)	20MHz Bandwidth	≤60mV
Short circuit protection		Continuous, and auto resume
Over temperature protection		150°C (max)
Over output voltage protection	SLD03 models SLD05 models	chip lock up diode clamp and chip lock up

## COMMON SPECIFICATIONS

Temperature ranges	Operating Power derating (above 55°C): Storage: Case temperature:	-25°C ~ +70°C 2% / °C -40°C ~ +105°C +95°C max
Hold-up time	(Vin=230VAC)	50ms(typ)
Humidity		95%(max)
Temperature coefficient		0.02%/°C
Switching frequency		100kHz(typ)
I/O-isolation voltage	SLD03 models SLD05 models	3000VAC/1 Min 4000VAC/1 Min
Leakage current		None
EMI/RFI conducted	SLD03 models SLD05 models	EN55022, level A EN55011, level A
EMC compliance	Electrostatic discharge ESD RF field susceptibility Electrical fast transients/bursts on mainsline SLD03 models SLD05 models SLD03 models SLD05 models	IEC/EN 61000-4-2 level 4 8kV/15kV IEC/EN 61000-4-3  IEC/EN 61000-4-4 level 3 2kV IEC/EN 61000-4-4 level 4 4kV IEC/EN 61000-4-5 level 3 1kV/2kV IEC/EN 61000-4-5 level 4 2kV/4kV
Safety standards	SLD03 models SLD05 models	IEC60950,EN60950,UL60950 IEC60601,EN60601
Safety approvals	SLD03 models SLD05 models	EN60950,UL60950 EN60601-1
Safety Class		CLASS II
Case material		UL94V-0
Install		PCB
MTBF		>300,000h @25°C

Note: External input pressure sensitive resistor is required to SLD03 models at inrush experiment, refer to typical application figure.

## TEMPERATURE VS LOAD

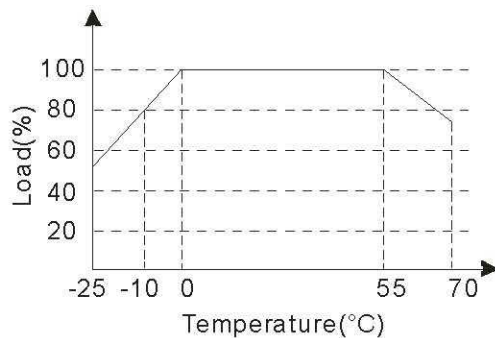

## INPUT VOLTAGE VS LOAD

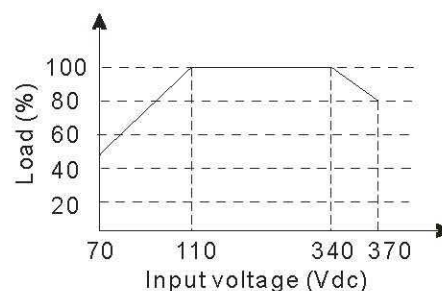
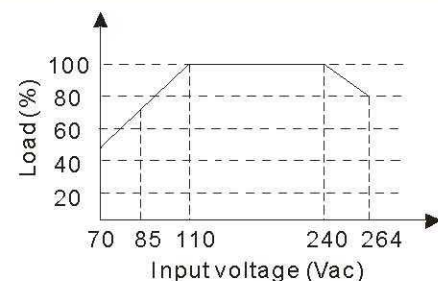

## TYPICAL EFFICIENCY CURVE

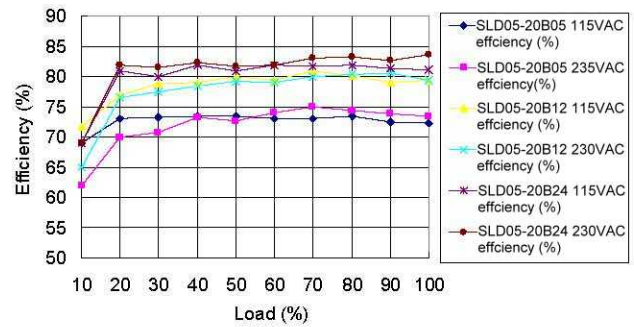
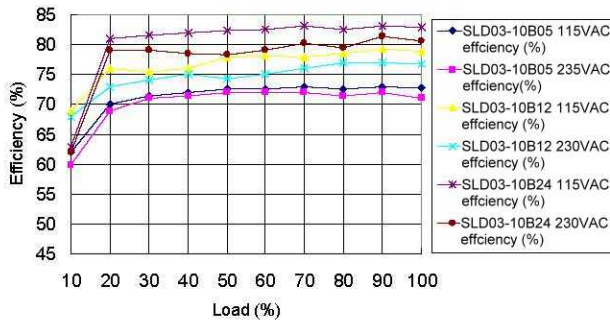

## ANEAR MEASURE

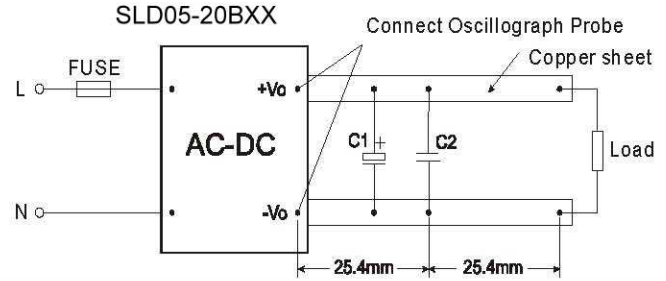
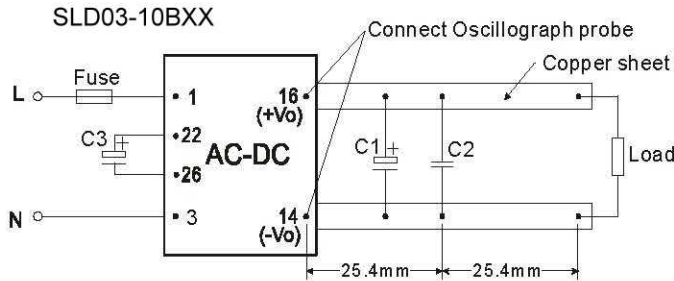

## TYPICAL APPLICATIONS

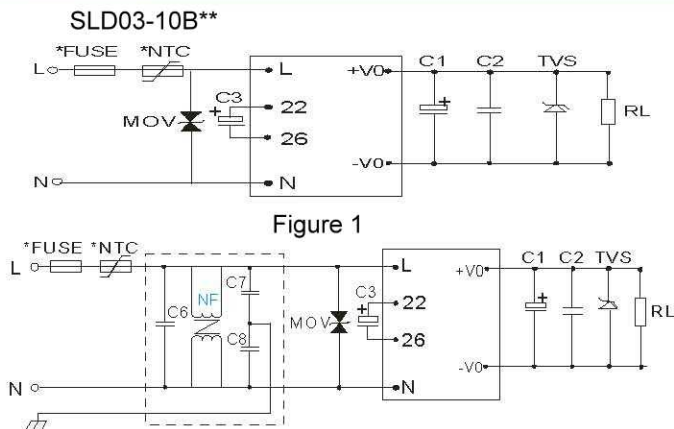

Figure3 SLD03 EMC Application Figure

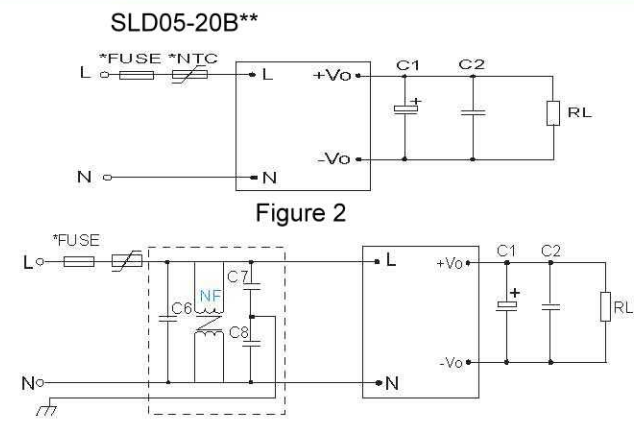

Figure4 SLD05 EMC Application Figure

### EXTERNAL CAPACITORS TYPICAL VALUE(Unit: $\mu\text{F}$ )

Model	C1	C2	C3	TVS	Model	C1	C2
SLD03-10B03	150	0.1	4.7/400V	P4KE6.8A	SLD05-20B03	47	0.1
SLD03-10B05	150	0.1	4.7/400V	P4KE6.8A	SLD05-20B05	47	0.1
SLD03-10B09	120	0.1	4.7/400V	P4KE12A	SLD05-20B09	33	0.1
SLD03-10B12	120	0.1	4.7/400V	P4KE20A	SLD05-20B12	33	0.1
SLD03-10B15	120	0.1	4.7/400V	P4KE20A	SLD05-20B15	33	0.1
SLD03-10B24	68	0.1	4.7/400V	P4KE30A	SLD05-20B24	10	0.1

#### Note:

- Output filtering capacitors C1, C3 is electrolytic capacitors, It is recommended to use high frequency and low impedance electrolytic capacitors. For capacitance and current of capacitor please refer to manufacture's datasheet. Voltage derating of capacitor should be 80% or above. C2 is ceramic capacitor, it is used to filter high frequency noise. TVS is a recommended component to protect post-circuits (if converter fails).
- MOV is required to SLD03 models, model: 471KD05, it is used to protect the device under surge.
- It is recommended to connect FUSE, the parameter for SLD03 models is 0.5A/250V slow blow, for SLD05 models is 1A/250V slow blow. External input NTC is recommended to use 5D-14 or 10 $\Omega$ /2W wire-round resistor.
- If EMC performance is required, recommended to add "EMC filter" at the input end(see figure 3,4)  
C6: X capacitor, recommended parameter 0.1 $\mu\text{F}$ /275V;  
C7,C8: Y capacitor, recommended parameter 2200pF/400V;  
NF: common model choke, recommended inductance is about 10mH-30mH.
- SLD03 models: Terminals 22 and 26 are internal rectification and filtering terminals. To protect the models further, it is recommended to connect an electrolytic capacitor C3 (it is recommended to be 4.7 $\mu\text{F}$ /400V). If operation voltage of the module is between 160-264VAC, C3 can be removed.

# OUTLINE DIMENSIONS & PIN CONNECTIONS

## SLD03-10BXX

**MECHANICAL DIMENSIONS**

(Bottom View)

(Side View)

FOOTPRINT DETAILS	
Pin	Function
1	L
3	N
13	NC
14	-Vo
16	+Vo
22	+Vin(DC)
26	-Vin(DC)

NC: No connection

**Note:**  
 Unit: mm[inch]  
 Pin section tolerances:  $\pm 0.10\text{mm}[\pm 0.004\text{inch}]$   
 General tolerances:  $\pm 0.25\text{mm}[\pm 0.010\text{inch}]$

**RECOMMENDED FOOTPRINT(TOP VIEW)**

**TUBE OUTLINE DIMENSIONS**

**Note:**  
 Unit :mm[inch]  
 General tolerances:  $\pm 0.50\text{mm}[\pm 0.020\text{inch}]$   
 L=530mm[20.866inch] pcs/tube: 13  
 L=220mm[8.661inch] pcs/tube: 5

## SD05-20BXX

**MECHANICAL DIMENSIONS**

(Bottom View)

(Side View)

FOOTPRINT DETAILS	
Pin	Function
1	N
2	L
3	+Vo
4	-Vo

**Note:**  
 Unit: mm[inch]  
 Pin section tolerances:  $\pm 0.10\text{mm}[\pm 0.004\text{inch}]$   
 General tolerances:  $\pm 0.25\text{mm}[\pm 0.010\text{inch}]$

**RECOMMENDED FOOTPRINT(TOP VIEW)**

**TUBE OUTLINE DIMENSIONS**

**Note:**  
 Unit :mm[inch]  
 General tolerances:  $\pm 0.50\text{mm}[\pm 0.020\text{inch}]$   
 L=530mm[20.866inch] pcs/tube: 19  
 L=220mm[8.661inch] pcs/tube: 7