

75 ohm SMB

For applications where low signal distortion is required such as computer, video and high speed data transfer, our SMB series with 75 ohm impedance is an ideal choice. The „snap.o“ coupling interface offers ease of installation and removal in high package density designs.

75 Ohm SMB:

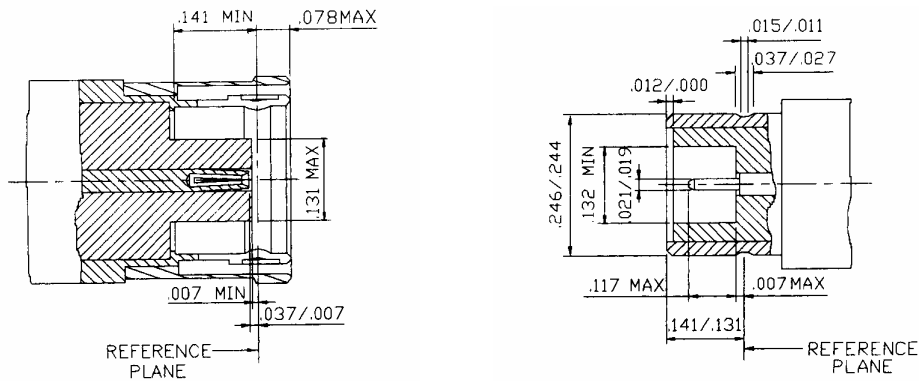

Notes: Unit of „Inch“

Straight Plug Crimp (75 ohm SMB)

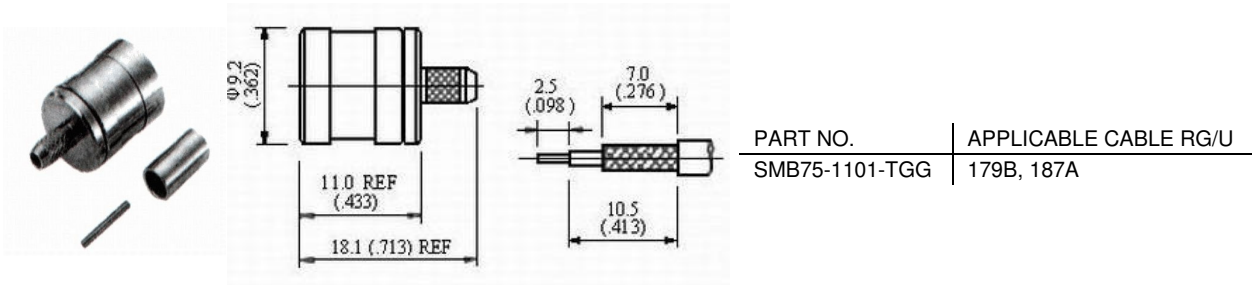

Description:
Flexible Cable-Crimp Attachment

Finish: Gold plated center contact & body
Insulation: Teflon

Right Angle Plug Crimp (75 ohm SMB)

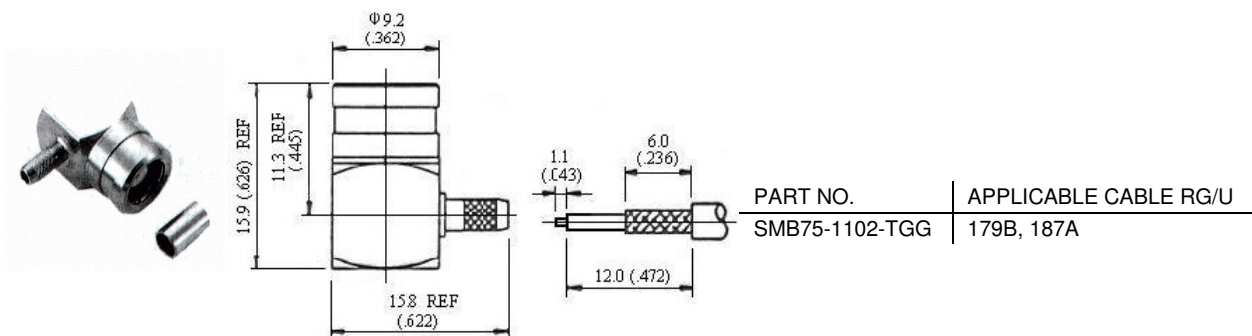

Description:
Flexible Cable-Crimp Attachment

Finish: Gold plated center contact & body
Insulation: Teflon

Straight Bulkhead Jack Receptacle (75 ohm SMB)

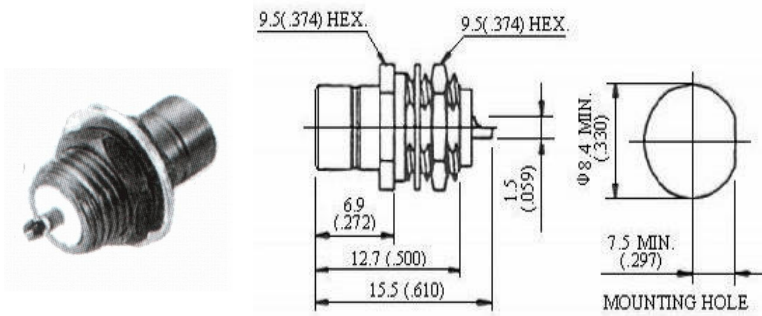

PART NO. _____
SMB75-4201-TGG

Description:
Bulkhead,PCB Mount Receptacles

Finish: Gold plated center contact & body
Insulation: Teflon

Straight PCB Mount Jack Receptacle (75 ohm SMB)

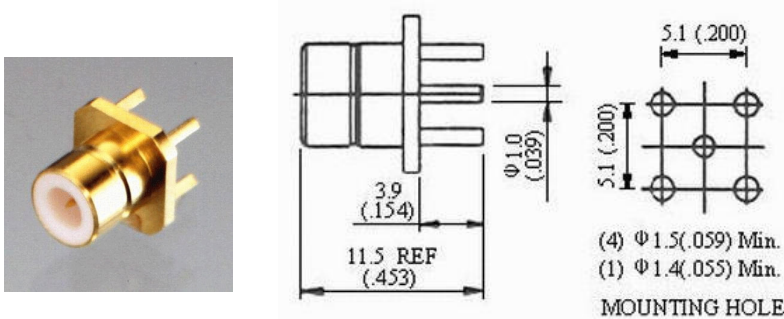

PART NO. _____
SMB75-5201-TGG

Description:
Bulkhead,PCB Mount Receptacles

Finish: Gold plated center contact & body
Insulation: Teflon